



**Memex Automation Inc.**  
777 Walkers Line,  
Burlington, Ontario Canada L7N 2G1  
<http://www.memex.ca>

---

## Fanuc 0 M/T Model C Serial (RS232) Connection Guide

---

The **Fanuc 0-C control** has two RS-232 interfaces. Interface number 1 (M5) can be wired to the external DB25 female connector or wired to a built-in tape reader interface (at 4800 baud). Interface number 2 (M74) is an option and can be wired to the external DB25 female connector. The baud rate and other parameters are set in NC parameters (see below). For cable and signal descriptions see our [Fanuc RS232 Communications](#) page or document at [www.memex.ca](http://www.memex.ca).



### Applicable Memory Cards (0-C and 0-4PC)

Memory Cards (MEM-A3)	A16B-1212-0210	Analog Spindle
	A16B-2201-0103	Analog Spindle
	A16B-1212-0215	16 bit, Serial Spindle
	A16B-1212-0216	32 bit, Serial Spindle
	A16B-2201-0101	32 bit, Serial Spindle

**Sample "C" Software Versions: 460,462,465,660,662,690,665,880,135...**

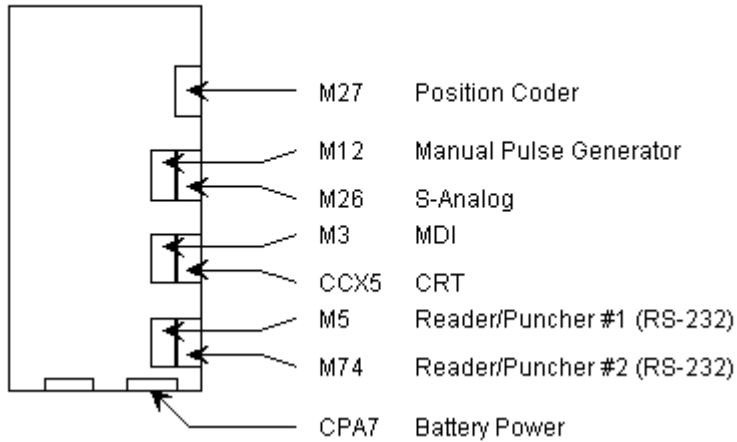

**\*See our MxBRU to replace the Fanuc battery pack**

## Communications Parameters

On the SETTINGS screen, set the following:

TVON = 0  
 ISO = 1  
 I/O = 0 (if using port 1), I/O = 2 (if using port 2)  
 PWE = 1  
 TAPEF = 0

CNC Parameter	Port 1 (M5)	Port 2 (M74)
0002	1xxxxx1	- -
0050	- -	1xxxxx1
0038	01xxxxxx	xx01xxxx
0552	10	- -
0253	- -	10

- - means that this parameter has no effect for this port.  
 X means that this bit is a "don't care" setting. Either 1 or 0 is OK

0038								Standard
RSCMD1	DEVFL1	RSCMD2	DEVFL2	FLKY	RSCMD3	DEVFL3		11001000
0002	FOR I/O SETTING = 0 (External RS232 Port)							
NFED	TJHD	PMXY2	PMXY2		ASR33	PPD	STP2	01000011
0012	FOR I/O SETTING = 1 (External RS232 Port)							
NFED	G84S	FXCO	FXCS		ASR33	ZILK	STP2	10000001
0050	FOR I/O SETTING = 2 (Internal Tape Reader)							
NFED				RSASCI			STP2	00000001
0051	FOR I/O SETTING = 3 (Optional Remote Buffer)							
NFED		ECLK	NCKCD	RSASCI	SYNAK	PARTY	STP2	00000000
0552	FOR I/O SETTING = 0 (External RS232 Port)							
BRATE0								10
0553	FOR I/O SETTING = 1 (External RS232 Port)							
BRATE1								11
0250	FOR I/O SETTING = 2 (Internal Tape Reader)							
BRATE2								10
0251	FOR I/O SETTING = 3 (Optional Remote Buffer)							
BRATE3								10

NB: Baud rate default here is 4800 (10), with protocol of E,7,2.

RSCMD1	DEVFL1	I/O DEVICE TO BE USED
0	0	Bubble Cassette
0	1	Floppy Cassette
1	0	RS232, PPR
1	1	New Interface

SETTING VALUE	BAUD RATE
1	50
2	100
3	110
4	150
5	200
6	300
7	600
8	1200
9	2400
10	4800
11	9600
*12	*19200

STP2	NUMBER OF STOP BITS
0	1 Stop Bit
1	2 Stop Bits

NFED	FEED CODE OUTPUT
0	Feed Is Output
1	Feed Is Not Output

\*19200 Baud is for I/O #2 & #3 Only!

Note also that Parameter 2

## Punching Procedure

- Punch NC Parameters* - *EDIT mode, PARAM screen, EOB + OUTPUT/START*
- Punch PC Parameters* - *EDIT mode, DGNOS screen, OUTPUT/START*
- Punch All Programs* - *EDIT mode, PRGRM screen, 0-9999, OUTPUT/START*
- Tool Offsets* - *EDIT mode, OFFSET screen, OUTPUT/START*

## Reading Procedure

- Load NC Parameters* - *EDIT mode, PARAM screen, EOB + INPUT*
- Load PC Parameters* - *EDIT mode, DGNOS screen, INPUT*
- Load All Programs* - *EDIT mode, PRGRM screen, INPUT*
- Load Tool Offsets* - *EDIT mode, OFSET screen, INPUT*

## Clearing Procedure

- Delete All memory - Power On holding RESET + DELETE keys with PWE=1
- Delete Parameters - Power On holding RESET key with PWE = 1
- Delete Programs - Power On holding DELETE key with PWE = 1

NB: PWE = Parameter Write Enable bit at Parameter 8000.0 in SETTING Page

## Standard Fanuc Serial Port: (DB-25 Female & Honda)

25 Pin Connector	PC-25 Pin Connector	25 Pin Connector	PC-9 Pin Connector
SG 7	7 SG	SG 7	5 SG
SD 2	2 SD	SD 2	2 RD
RD 3	3 RD	RD 3	3 SD
RS 4	4 RS	RS 4	7 RS
CS 5	5 CS	CS 5	8 CS
DR 6	6 DR	DR 6	6 DR
CD 8	8 CD	CD 8	1 CD
ER 20	20 ER	ER 20	4 ER

- 1 = Frame Ground
- 2 = Transmit Data
- 3 = Receive Data
- 4 = Ready To Send
- 5 = Clear To Send
- 6 = Data Set Ready
- 7 = Signal Ground
- 8 = Carrier Detect
- 20 = Error (Data Terminal Ready)
- 25 = +24 Volts

The usual software handshaking cable configuration with a DB25 has 2, 3 crossed & 7 connected straight through with Pins 4&5 jumpered (or brought through if hardware handshaking is enable which we recommend by the way), and lastly pins 6,8 & 20 jumpered on the control side only.

The Fanuc Honda Connector (M5 or M74) is wired as such:

- 9 = Transmit Data
- 8 = Receive Data
- 20 = RTS
- 19 = CTS
- 5 = DTR ---\
- 18 = DSR ---/ <-- Can be brought out or jumpered directly to prevent 86 CD Alarms
- 16 = CD ---/
- 17 = GND
- 10 = FG or Shield
- 14 = +24VDC

The usual software handshaking cable configuration with a DB25 has 2, 3 crossed & 7 connected straight through (with 4&5 jumpered - or used if hardware handshake lines are preferred) and pins 6,8 & 20 jumpered on the control side only.

## Fanuc ISO Protocol: (E,7,x)

The standard protocol for Fanuc controls is 4800 or 9600 Baud, "Even parity", "7 data bits" and either "1 or 2 stop bits" using DC1-4 Codes (XON/XOFF, PUNCH ON/OFF). See Parameters above.

## Determination of Fanuc 0 Model Types

To determine the version of the Fanuc 0 series CNC Control, check the master board number and/or the software version. The Master board number is found on the top left side of the main circuit board, usually mounted in the control cabinet that has the daughter card attached. It should not be confused with "A02B-????-?????" numbers, which are Fanuc's ordering numbers and are usually found on a sticker above the master board.

You can determine the software version by powering-up the control with E-stop active (button depressed). The control should hang on the software version screen (in the lower right corner of this screen, you will see the servo version number as well). Please note that Memex has a MxBRU (Battery Replacement Unit) available that provides a maintenance-free rechargeable Lithium battery backup for this control.

1985 / 1986 Fanuc 0-MA and Fanuc 0-TA 120M maximum battery backed resident memory.

1987 / 1989 Fanuc 0-MB and Fanuc 0-TB 320M maximum battery backed resident memory.

1990 / 1998 Fanuc 0- MC and Fanuc 0-TC 320M maximum battery backed resident memory.

## Fanuc 0 DNC Drip-Feeding Note

Most machine tool builders enabled the ability for the CNC to run in drip feed mode (also called "Tape" mode, or "Auto" mode with a switch or keep relay set). You can determine if your machine supports running files of any length in this mode that executed each line directly if you can make the "DNCI" bit in the Diagnostics area go to a "1". The "DNCI" bit is G127.5 (or Diagnostic bit 127 = xx1x xxxx). If you have a switch, keep relay (found in the Diagnostic section by the way) then you are good to go. Put the machine in DNC mode, make sure you are in AUTO mode, get your PC ready to send the file and hit Cycle Start to start executing code. The code never goes into the part program memory, so code of any length can be run. Make sure you have a good DNC setup as any data loss (due to bad cabling or faulty flow control) can cause a crash. Try our NetDNC software for a reliable communications link available as a free demo on our website.

(Note: If you have a Fanuc 0-M Model A (Digital) with a A16B-1010-0210 masterboard and software version 412-08, we have a special DNC solution for you).